

CONVENTIONAL SMOKE DETECTOR

MODEL NO- C-100PD



The conventional smoke detectors are designed to work with all make conventional Panels.

This is new-generation product with built-in microprocessor which make it stable and reliable performance. When the detector checks fire signal, it will send fire information to the control panel or addressable zone monitor unit by means of current changing. The detector keeps turning on the LED to indicate alarm state until it is reset.

It is suitable for detecting smoke in Houses, Stores, Hotels, and Warehouses etc.

The 100 series detectors require the 100-SB base in order to connect. Detector maximum installation height is 3.5 meters.

Features and Benefits :

- Sleek Low Profile Housing Design.
- Highly Reliable and reduce the false alarm.
- Easy Installation.
- Dual LED for 360°visibility.
- Blink green in normal condition and steady red in case of fire.
- Network Relay Output for RI.
- Infrared Photo electric sensor.

☎ +91-8527498960, 8527498961, 8527498962

✉ sales@agniprotection.com, support@agniprotectionindia.com

🌐 www.agniprotection.com



An ISO 9001-2008 Certified Co.
AGNI PROTECTION PVT. LTD.
DATASHEET

- Dustproof, anti-light interference design.
- Low standby current.
- Compatible With All Make Conventional Fire Alarm and Zone Monitor Module.
- Bi-Colour LED Status Indicator.
- RI Blinking in case of normal Mode.

Technical Specifications :

Product Design	2 Wire
Operating Voltage	16-30 V DC
Standby Current	75 pA.
Current Consumption at Alarm Condition	25 mA
LED Indication	Present
Sensor	Photoelectric& thermistor
Quiescent Current	≤ 75uA
Blinking Cycle	12 sec.
Installation Method	Ceiling Mounted

ENVIRONMENTAL INFORMATION:

Operating Temperature	0° C to + 65° C
Operating Humidity	5 to 95% Relative Humidity (noncondensing)

MECHANICAL SPECIFICATION:

Hight	52.4
Diameter	106 MM
Colour	White
Weight	150 gm
Housing	ABS FR

☎ +91-8527498960, 8527498961, 8527498962

✉ sales@agniprotection.com, support@agniprotectionindia.com

🌐 www.agniprotection.com

MECHANICAL DESIGN:

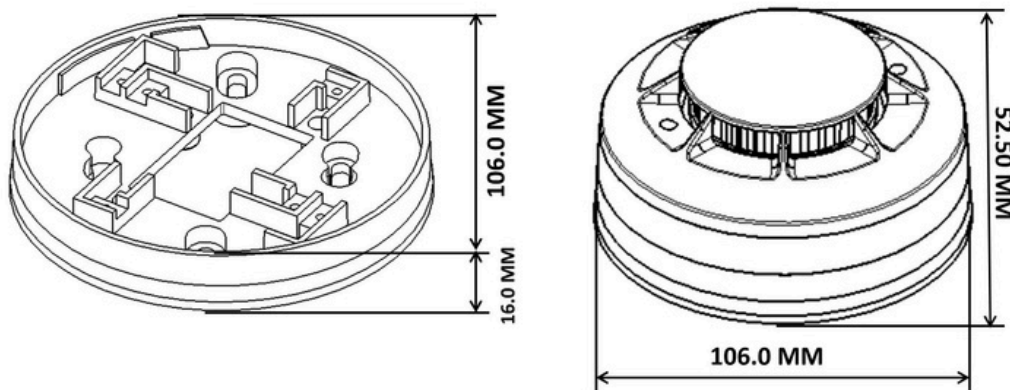

WIRING DIAGRAMS:

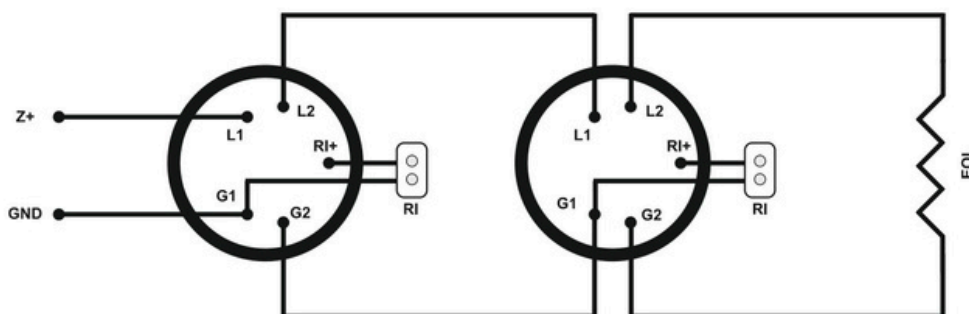



An ISO 9001-2008 Certified Co.
AGNI PROTECTION PVT. LTD.
DATASHEET

WIRING GUIDLINES:

- All the wire installation must accord with National and local effective laws and criteria.
- All wires must have the suitable size and must have colour coding to avoid connection errors. And unsuitable connection will lead to alarm error when Fire happens.
- The product should not be installed in the extreme hot or cold, high wind speed surroundings and in the conditions where there is often a lot of smoke or dust.
- The detector needs to be tested every 2 months.
- The product can reduce the possibility of accidents, but it cannot guarantee absolute safety. Besides using this product correctly.
- The dust cover cannot be removed until the project has been plunged into usage. Otherwise, it can't alarm normally.
- Clean the detector at least once a year to ensure normal operation of the system.

ORDERING INFORMATION:

MODEL NO	PACK QTY.	DIMESION (WXHXD) MM	WEIGHT
C-100PD	1	106	150 gm

APPROVED BY:



+91-8527498960, 8527498961, 8527498962

sales@agniprotection.com, support@agniprotectionindia.com

www.agniprotection.com