

## CONVENTIONAL MULTI CRITERIA DETECTOR

### MODEL NO- C-100PHD



The conventional Multi criteria detectors are designed to work with all make conventional Panels.

This is new-generation product with built-in microprocessor which make it stable and reliable performance. When the detector checks fire signal, it will send fire information to the control panel or addressable zone monitor unit by means of current changing. The detector keeps turning on the LED to indicate alarm state until it is reset.

This 100 Series Multi-criteria detector is combination of smoke and heat sensor by which it gives more accurate determination about the presence of fire.

This Approach Help Reduce False Alarm caused by environmental factor that might trigger single- sensing Detector.

It is suitable for detecting smoke in Laboratories, Hospitals, Hotels, and Power Generation Facilities, Data centres, Transportation systems etc.

The 100 series Multi Criteria detectors require the 100-SB base in order to connect.

The integral LED changes colour according to the detector's status, Green = Normal, Red = Alarm. This benefits the user by providing clear, instant visual indication of the detector's conditions.

☎ +91-8527498960, 8527498961, 8527498962

✉ sales@agniprotection.com, support@agniprotectionindia.com

🌐 [www.agniprotection.com](http://www.agniprotection.com)



An ISO 9001-2008 Certified Co.  
**AGNI PROTECTION PVT. LTD.**  
DATASHEET

## Features and Benefits :

- Sleek Low Profile Housing Design.
- Highly Reliable and reduce the false alarm.
- Easy Installation.
- Dual LED for 360°visibility.
- Blink green in normal condition and steady red in case of fire.
- Network Relay Output for RI.
- Combination of Infrared Photo electric sensor and thermistor.
- Dustproof, anti-light interference design.
- Low standby current.
- Compatible With All Make Conventional Fire Alarm and Zone Monitor Module.
- Bi-Colour LED Status Indicator.
- RI blinking in normal mode.

## Technical Specifications :

Product Design	2 Wire
Operating Voltage	16-30 V DC
Standby Current	75 pA.
Current Consumption at Alarm Condition	25 mA
LED Indication	Present
Sensor	Photoelectric& thermistor
Quiescent Current	≤ 75uA
Blinking Cycle	12 sec.
Installation Method	Ceiling Mounted

## ENVIRONMENTAL INFORMATION:

Operating Temperature	0° C to + 65° C
Operating Humidity	5 to 95% Relative Humidity (noncondensing)

☎ +91-8527498960, 8527498961, 8527498962

✉ sales@agniprotection.com, support@agniprotectionindia.com

🌐 [www.agniprotection.com](http://www.agniprotection.com)

### MECHANICAL SPECIFICATION:

Hight	52.4
Diameter	106 MM
Colour	White
Weight	150 g
Housing	ABS FR

### MECHANICAL DESIGN:

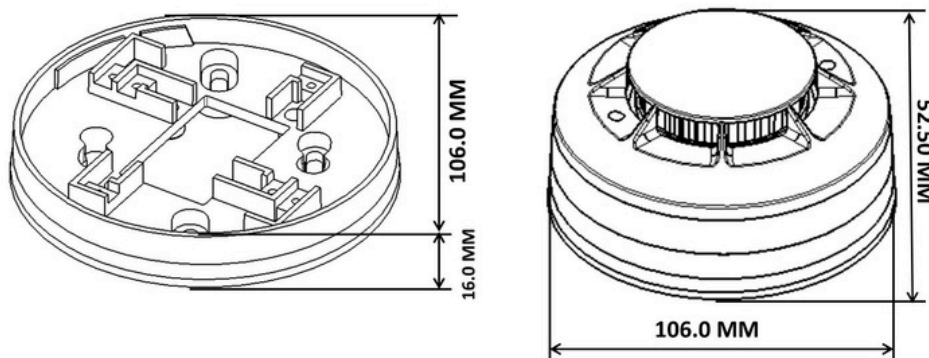

### WIRING DIAGRAMS:

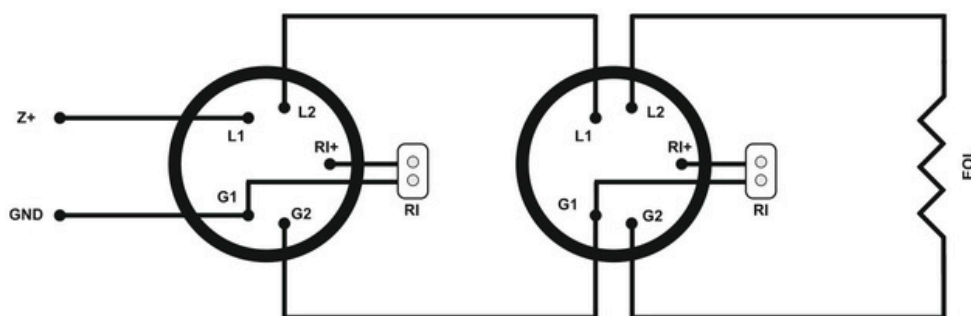

+91-8527498960, 8527498961, 8527498962

sales@agniprotection.com, support@agniprotectionindia.com

www.agniprotection.com



An ISO 9001-2008 Certified Co.  
**AGNI PROTECTION PVT. LTD.**  
DATASHEET

### WIRING GUIDLINES:

- All the wire installation must accord with National and local effective laws and criteria.
- All wires must have the suitable size and must have colour coding to avoid connection errors. And unsuitable connection will lead to alarm error when Fire happens.
- The product should not be installed in the extreme hot or cold, high wind speed surroundings and in the conditions where there is often a lot of smoke or dust.
- The detector needs to be tested every 2 months.
- The product can reduce the possibility of accidents, but it cannot guarantee absolute safety. Besides using this product correctly.
- The dust cover cannot be removed until the project has been plunged into usage. Otherwise, it can't alarm normally.
- Clean the detector at least once a year to ensure normal operation of the system.

### ORDERING INFORMATION:

MODEL NO	PACK QTY.	DIMESION (WXHXD) MM	WEIGHT
C-100PHD	1	106	150 gm

### APPROVED BY:



+91-8527498960, 8527498961, 8527498962  
sales@agniprotection.com, support@agniprotectionindia.com  
www.agniprotection.com